

# THUNDERBIRD-R LED-TYPE 3 CUT-OFF LUMINAIRE

## Single Source Responsibility – Up to 18 Year Maintenance Cycle



### FEATURES

- 40-60% energy reduction
- 70% maintenance reduction
- Replaces up to 250HPS-400MH
- Prisms hide LED glare
- Premium American LED's
- Thermal protection circuit
- Replaceable components
- Exceeds DOE Reliability Standards
- White 4100K – 70% CRI

### BENEFITS

- Qualifies for Federal & Utility rebates
- Greatly reduced owning cost
- Versatile
- Provides white light visibility
- No driver discomfort
- Best components
- Easily maintained if necessary
- Tested for long life
- Excellent color rendition

### APPLICATIONS

- Street lighting
- Parking Areas
- Solar Power

## Specifications/Features

### GENERAL

- Premium LED Streetlight
- Retrofits 100-250 HPS & 250-400MH
- LED with refractor provides cut-off distribution
- Prismatic refractor hides led brightness
- Provides up to 7 to 1 spacing
- Choice of 350 or 500ma operation

### CONSTRUCTION

- Die-cast aluminum housing
- 8 oz finned aluminum heat sinks
- Replaceable parts with plug in connectors
- Stainless steel hardware
- Non-yellowing acrylic refractor
- Optional glass refractor
- Luxeon Rebel LEDs

### OPTICAL ADVANTAGE

The patent pending optical system maximizes light on the task, eliminates excess light under the fixture and almost all light above 90 degrees. The exceptional uniformity reduces eye fatigue, aids visibility and increases safety

### ELECTRICAL/WARRANTY

- 120-277V Advance driver
- 24V LED operation
- LED boards wired in parallel
- Consult factory for 347/480V
- Consult factory for solar operation
- Surge protected driver
- Instant on after power outage
- 5 Year limited warranty
- -40°F starting
- Less than 10% failures at 60K hours
- Less than 30% lumen depreciation at 60K hrs.

### DEPT of ENERGY LM80 TEST DATA

Guth Luxeon Rebel LEDs exceeds Energy Star guidelines intended to ensure quality solid state development. The LEDs have lumen maintenance of 98.9% after 6,000 hours while operated at 350ma with an 85°C junction temperature.

Patent Pending Optical System



# Photometrics

TBR-32L-5-U  
20' ROAD – 28' MH  
140' Staggered Spacing

Avg.	.83 FC
Max	1.17 FC
Min	.64 FC
Max/Min	1.8 to 1
Avg/Min	1.3 to 1

TBR-32L-5-U  
20' ROAD – 28' MH  
140' Spacing – One Side

Avg.	.43 FC
Max	.87 FC
Min	.31 FC
Max/Min	2.8 to 1
Avg/Min	1.4 to 1

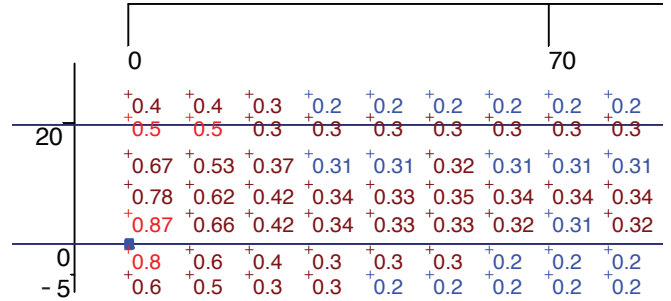
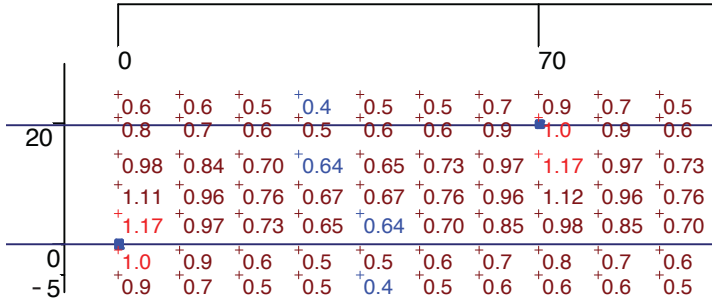

# Dimensions

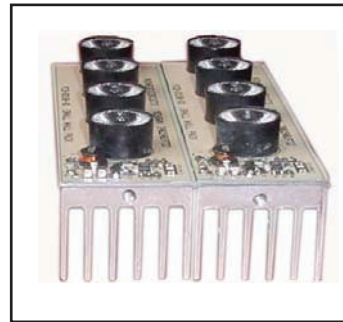
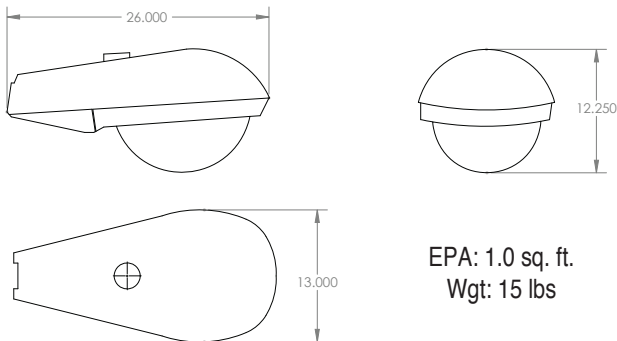

LED Heat Sink

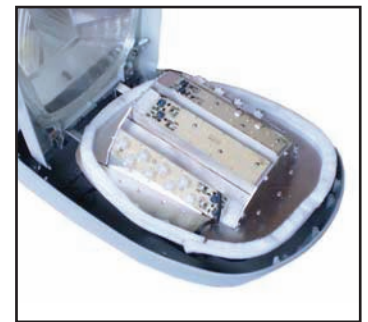

Patent Pending Optics

# THUNDERBIRD - R Catalogue Numbers

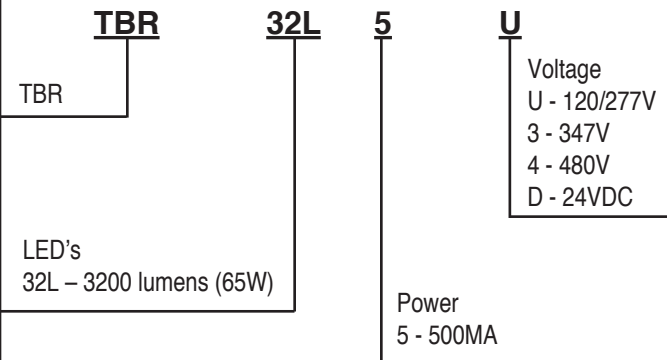

Note: 350ma operation reduces light levels 20-25%

# Options

- "/PC" – photo control receptacle
- "BL" – Bi-Level Control (consult factory)
- "UL" – UL Listed (not required for roadway lighting)

Project Name:

Type	Catalogue Number	Comments

Guth utilizes the services of U.L. and ETL for listing products. Specifications and data are subject to change without notice.

Guth Lighting is a Philips group brand - 04/10