

SEELUX™

H.I.D. Recessed Round



FEATURES

- Up to 250 Watt HID
- Plaster or grid ceiling
- High efficiency Alzak reflector
- Aluminum door
- 85 Watt Induction Lamp
- Pulse start MH

BENEFITS

- Requires less fixtures
- Lasting appearance
- Indoor & outdoor

APPLICATIONS

- Canopies
- Corridors
- Commercial
- Schools
- Corrosive environments
- Kitchens

Specifications/Features

GENERAL

- Standard lens is circular prismatic 3/8" thick sealed in lens frame.
- H.I.D. sources up to 250 watt. Incandescent sources up to 300 watt.
- 1" Regressed trim flange of die-cast aluminum. Eliminates high angle glare.
- Sealed door frame and lens to prevent air movement past fixture.
- Low profile ideal for shallow plenums.
- Fits either ceiling grid systems or plaster ceilings.

CONSTRUCTION

- Electro-galvanized steel mounting pan supports reflector door frame and ballast.
- Reflector hydroformed of rigid .060" aluminum with Alzak finish.

DOOR FRAME/LENS

- Die-cast door frame held tightly to ceiling by torsion springs that also hold frame captive when relamping. Approximately 13 inches in diameter.



Torsion springs draw door frame tight to ceiling plane.



Die-cast door houses prismatic lens for wide light distribution. Deep regressed door keeps energy efficient H.I.D. lamps low in brightness for higher footcandle levels from a single luminaire.

LISTINGS

- Listed for use in U.S.A. and Canada.

ELECTRICAL

- HID Ballasts for 120 and 277 volt are potted, "F can," Class P mounted to steel pan and prewired.
- Ballasts for other voltages installed in aluminum ballast housing mounted to steel pan and connected to lampholder and junction box by pre-wired flex conduit.
- All fixtures carry the IBEW Union label to insure quality.

Photometrics

Coefficients of Utilization 1 Lamp, 175W CLR MH B11-517

Ceiling Refl.	80%			50%			10%		
Wall Refl.	50	30	10	50	30	10	50	30	10
RCR	20% Effective Floor Cavity Reflectance								
1	.71	.70	.68	.67	.66	.65	.62	.62	.61
2	.66	.63	.61	.62	.60	.59	.58	.57	.56
3	.60	.57	.54	.58	.55	.53	.55	.53	.51
4	.56	.52	.49	.54	.51	.48	.51	.49	.47
5	.52	.48	.45	.50	.47	.44	.48	.45	.43
6	.48	.44	.41	.47	.43	.40	.45	.42	.40
7	.45	.41	.38	.44	.40	.37	.42	.39	.37
8	.42	.38	.35	.41	.37	.35	.40	.37	.34
9	.40	.35	.32	.39	.35	.32	.38	.34	.32
10	.37	.33	.30	.37	.33	.30	.36	.32	.30

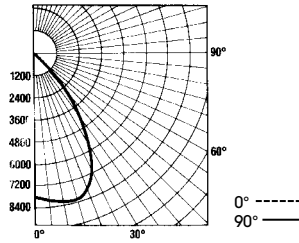

S/MH Ratio 1.1:1
Total Lamp Lumens 15,000
Fixture Efficiency 65%

Report No.
P11354A

Coefficients of Utilization 1 Lamp, 150W CLR HPS B11-520

Ceiling Refl.	80%			50%			10%		
Wall Refl.	50	30	10	50	30	10	50	30	10
RCR	20% Effective Floor Cavity Reflectance								
1	.75	.74	.72	.71	.70	.69	.66	.65	.65
2	.69	.67	.64	.66	.64	.62	.62	.60	.59
3	.64	.60	.57	.61	.58	.56	.57	.56	.54
4	.59	.55	.52	.57	.53	.51	.54	.52	.50
5	.55	.50	.47	.53	.49	.46	.51	.48	.45
6	.51	.46	.43	.49	.45	.42	.47	.44	.42
7	.47	.43	.39	.46	.42	.39	.44	.41	.39
8	.44	.40	.36	.43	.39	.36	.42	.38	.36
9	.41	.37	.34	.40	.36	.33	.39	.36	.33
10	.39	.34	.31	.38	.34	.31	.37	.33	.31

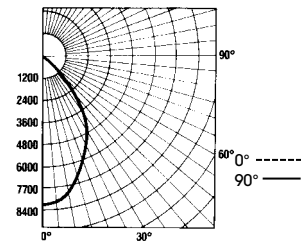

S/MH Ratio 1.1:1
Total Lamp Lumens 16,000
Fixture Efficiency 69%

Report No.
P11354

Dimensions

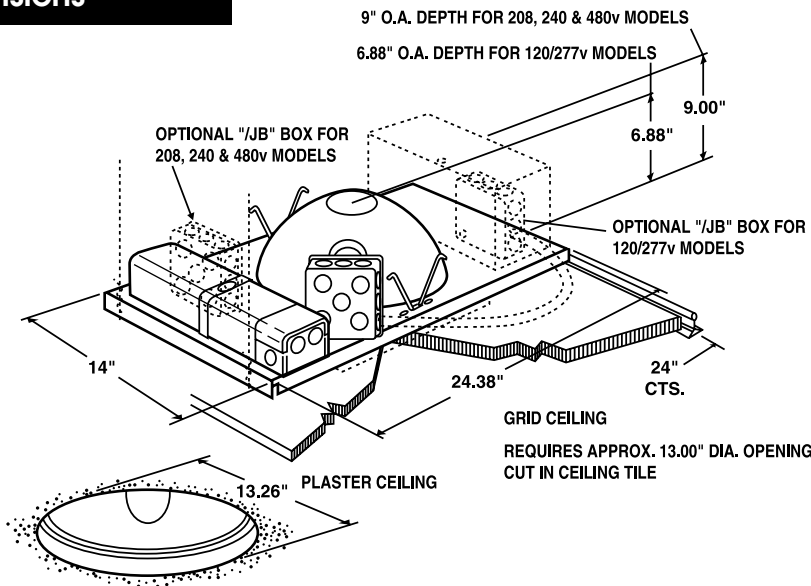

Note: Uses Horizontal Burning Lamp

Seelux™ Catalog Numbers

Catalog Number	Description	Total Watts
B11501/120	200-300W INC., PS25 Lamp, 14" Dia.	200-300
B11514/120	250W MH., E-28, BT-28 Lamp, 14" Dia.	295
B11515/120*	35W HPS., E-17 Med Lamp, 14" Dia.	55
B11516/120	50W HPS., E-23-1/2 Lamp, 14" Dia.	65
B11560/120	70W MH., ED-17 Lamp, 14" Dia.	90
B11561/120	100W MH., ED-17 Lamp, 14" Dia.	125
B11562/120	150W MH., ED-17 Lamp, 14" Dia.	185
B11517/120	175W MH., BT-28 Lamp, 14" Dia.	215
B11518/120	70W HPS., E-23-1/2 Lamp, 14" Dia.	94
B11519/120	100W HPS., E-23-1/2 Lamp, 14" Dia.	130
B11520/120	150W HPS., E-231/2 Lamp, 14" Dia.	188
B11565/120	85W QL Induction Lamp, 14" Dia.	85

*No. 277V, reactor ballast only.
Note: Listed and tested inside a box. Size: 47" x 47" x 11".

Guth utilized the services of U.L. and ETL for listing products.
Specifications and data are subject to change without notice.

Options

- "/FF" - Fixture Fuse
- "/JB" - Thru-wire Junction Box
- "/NL" - Nite Lite (Maximum 40W)
- "/TP" - Tamper Proof Screws
- "/ISL" - Instant Standby Quartz
- "/LIP" - 2' x 2' Grid Metal Lay-In Pan
- "/PS" - Pulse Start Metal Halide

Project Name:

Type	Catalogue Number	Lamp	Comments

GUTH
a GENLYTE company

H 4
R7/07